

Allen screw M5X6
T.C.E.I.
Cod.201044

Db-Killer ϕ 22
Cod.303430801

GP CORSA
 ϕ i 54X240 RHS
Cod.303457473

Knurled collar nut
M8 Cod.200298

Silencer clamp
Cod.303396501

Flange
cod.206606

Welded bushing S.s
cod.206608

OPTIONAL
cod.5683

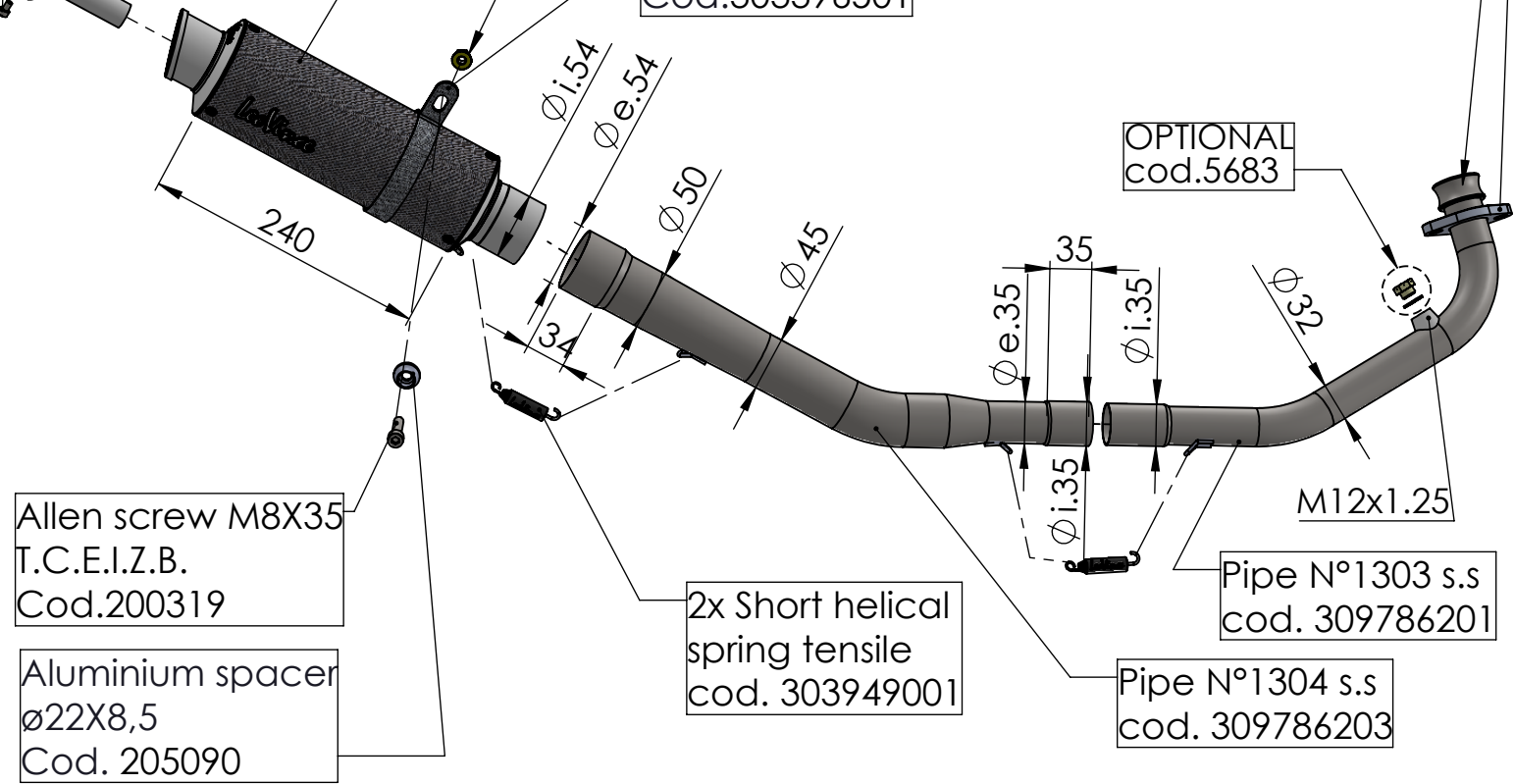

Allen screw M8X35
T.C.E.I.Z.B.
Cod.200319

Aluminium spacer
 ϕ 22X8,5
Cod. 205090

2x Short helical
spring tensile
cod. 303949001

Pipe N°1303 s.s
cod. 309786201

Pipe N°1304 s.s
cod. 309786203

WARNING

it is advisable to optimize the carburation by remapping the stock ECU or by adopting an additional ECU unit.

ART. 9786C

HONDA WINNER 150 FI

FULL SYSTEM - GP CORSA - CARBON